



THE DIESELWORKS

INSTRUCTIONS

Please keep these instructions for future reference as they contain important information.

ASSEMBLY

- 1 Unfold the track into the track layout, as shown.

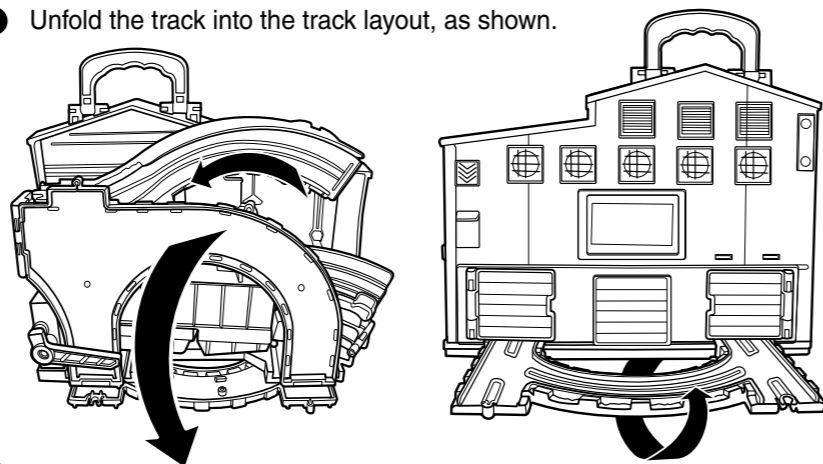

- 2 Snap in the two track supports

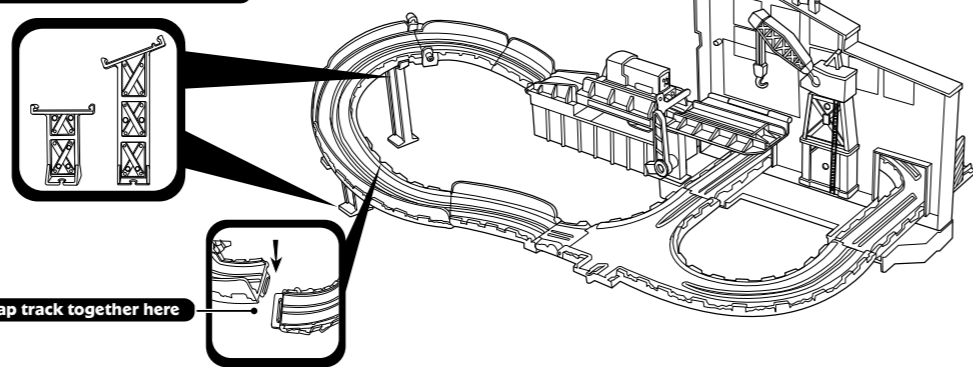

HOW TO PLAY

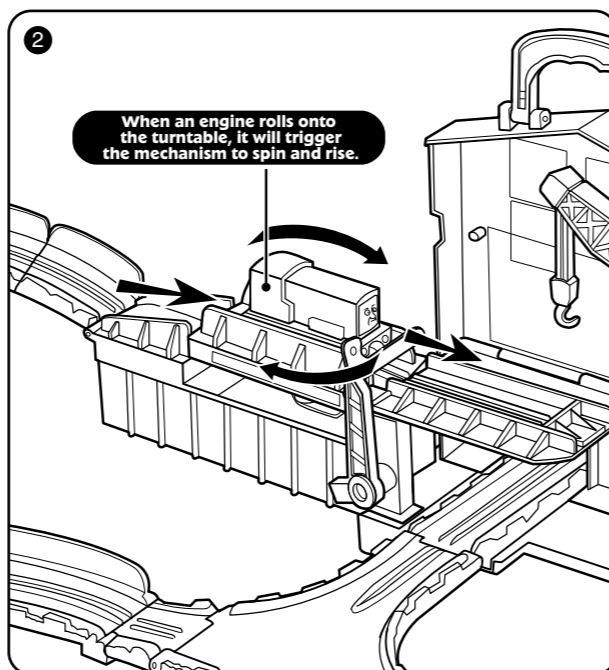
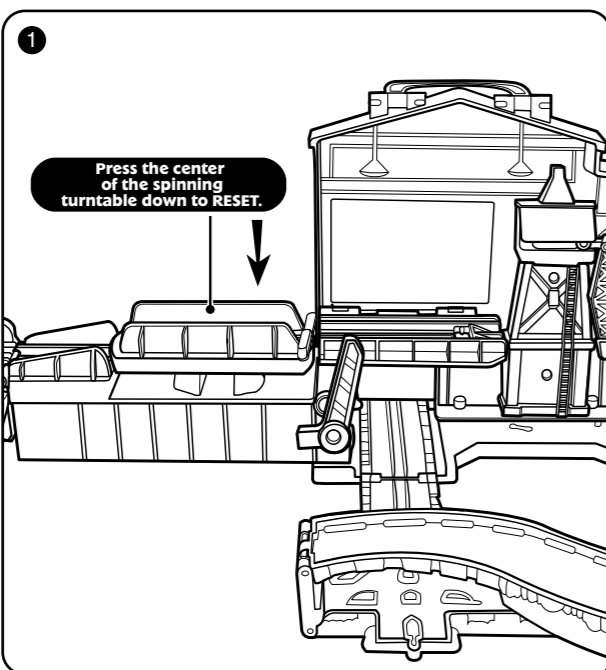

STORAGE

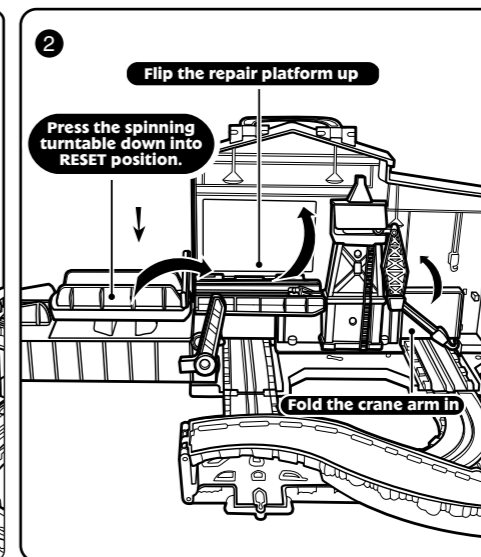
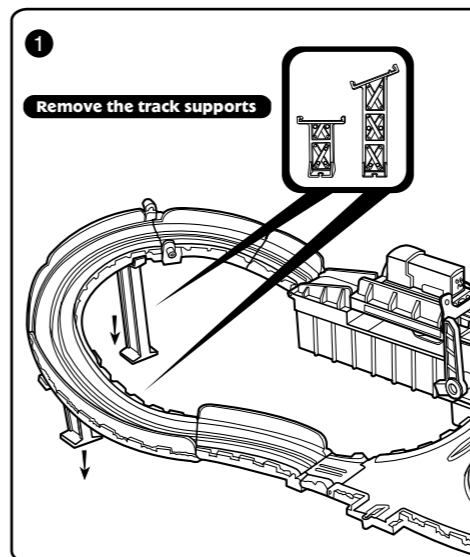

- 3 Fold the tracks in, as shown.

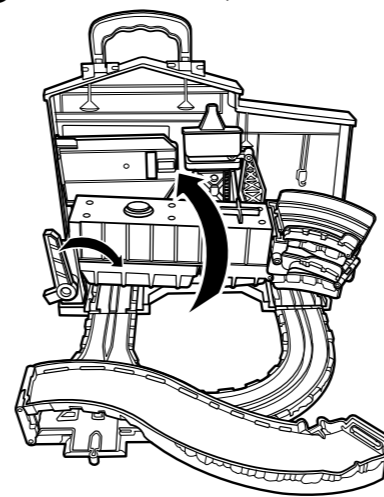

- 4 Flip the bottom piece under.

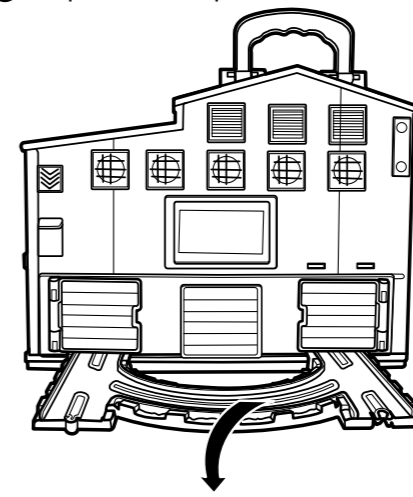

- 5 Store the track supports by snapping them to the folded track, as shown.

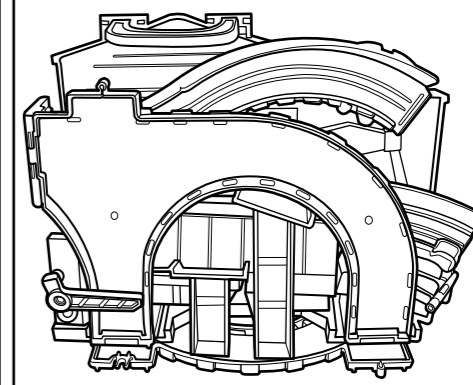

NOTE: May not work with all engines.

Thomas the Tank Engine & Friends™
 CREATED BY BRIT ALLCROFT
 Based on the Railway Series by The Reverend W Awdry.
 © 2011 Gullane (Thomas) Limited.
 Thomas the Tank Engine & Friends and
 Thomas & Friends are trademarks of Gullane (Thomas) Limited.
 © HIT Entertainment Limited. HIT and the HIT logo
 are trademarks of HIT Entertainment Limited.
 Fisher-Price, Inc., a subsidiary of Mattel, Inc.,
 East Aurora, NY 14052, U.S.A.
PRINTED IN CHINA. Manufactured for Fisher-Price.
 © 2011 Mattel, Inc. All Rights Reserved.
 ® and ™ designate U.S. trademarks of Mattel, Inc.,
 unless otherwise indicated.
 Mattel East Asia Ltd., Room 1106, South Tower,
 World Finance Centre, Harbour City, Tsimshatsui, HK, China.

CONSUMER ASSISTANCE
 1-800-432-5437 (US & Canada)
 1300 135 312 (Australia)
service.fisher-price.com

Fisher-Price, Inc., 636 Girard Avenue, East Aurora, NY 14052.
 Hearing-impaired consumers: 1-800-382-7470.

Outside the United States:
 Canada: Mattel Canada Inc., 6155 Freemont Blvd.,
 Mississauga, Ontario L5R 3W2; www.service.mattel.com.
 Great Britain: Mattel UK Ltd, Vanwall Business Park,
 Maidenhead SL6 4UB, Helpline: 01628 500303.
 www.service.mattel.com/uk
 Mattel Europa, B.V., Gondel 1, 1186 MJ Amstelveen, Nederland.
 Australia: Mattel Australia Pty. Ltd., 658 Church Street,
 Locked Bag #870, Richmond, Victoria 3121 Australia.
 New Zealand: 16-18 William Pickering Drive,
 Albany 1331, Auckland.



ID: V7638-0920G1

6/10/11 Remark for G1
 - Add the 5th step and copies.

Item No : V7638-0920G1
 Version : EL
 Size : A4
 Paper : Woodfree paper 70 gsm
 Color : Black
 Date :